

Flexible D-STATCOM Performance in Mitigating Faults

MEGHAVATH SAIKUMAR¹, DHARAVATH REDYA²

¹UG Scholar, Dept of EEE, Sree Dattha Institute of Engineering & Science Hyderabad, India.

²Associate Professor, Dept of EEE, Sree Dattha Institute of Engineering & Science Hyderabad, India.

Abstract: This paper proposes a flexible D-STATCOM (Distribution Static COMPensator) and its new controller system, that be able to both mitigate all types of faults and operate as a Distributed Generation (DG), when it supplies power to sensitive loads while the main utility source is disconnected (i.e. it is under islanded operating condition). Thus D-STATCOM operates same as a flexible DG (FDG) and consequently, it is called Flexible DSTATCOM (FD-STATCOM). This paper validates the performance of FD-STATCOM system to mitigate power quality problems and improve distribution system performance under all types of system related disturbances and system unbalanced faults, such as Line-to-Line (LL) and Double Line to Ground (DLG) faults and supplies power to sensitive loads under islanding condition. The work had been carried out in MATLAB environment using Simulink and SIM power system tool boxes. The proposed D-STATCOM model is very effective to enhance the power quality of an isolated distribution system feeding power to crucial equipment in remote areas. The simulations were performed and results were found to be satisfactory using MATLAB/SIMULINK.

Keywords: Statcom, Facts Controllers, D-Statcom, Voltage Source Converter, Total Harmonic Distortions.

I. INTRODUCTION

An Increasing demand for high quality, reliable electrical power and increasing number of distorting loads may leads to an increased awareness of power quality both by customers and utilities. The most common power quality problems today are voltage sags, harmonic distortion and low power factor. Voltage sags is a short time (10 ms to 1 minute) event during which a reduction in rms voltage magnitude occurs. It is often set only by two parameters, depth/ magnitude and duration. The voltage sags magnitude is ranged from 10% to 90% of nominal voltage and with duration from half a cycle to 1 min. Voltage sags is caused by a fault in the utility system, a fault within the customer's facility or a large increase of the load current, like starting a motor or transformer energizing. Voltage sags are one of the most occurring power quality problems. For an industry voltage sags occur more often and cause severe problems and economical losses. Utilities often focus on disturbances from end-user equipment as the main power quality problems. Harmonic currents in distribution system can cause harmonic distortion, low power factor and additional losses as well as heating in the electrical

equipment. It also can cause vibration and noise in machines and malfunction of the sensitive equipment. The development of power electronics devices such as Flexible AC Transmission System (FACTS) and customs power devices have introduced and emerging branch of technology providing the power system with versatile new control capabilities. There are different ways to enhance power quality problems in transmission and distribution systems. Among these, the D-STATCOM is one of the most effective devices. A new PWM-based control scheme has been implemented to control the electronic valves in the DSTATCOM. The D-STATCOM has additional capability to sustain reactive current at low voltage, and can be developed as a voltage and frequency support by replacing capacitors with batteries as energy storage.

II. CONCEPT OF POWER QUALITY

A. Introduction to Power Quality

Power quality is the set of limits of electrical properties that allows electrical systems to function in their intended manner without significant loss of performance or life. The term is used to describe electric power that drives an electrical load and the load's ability to function properly with that electric power. A perfect power supply would be one that is always available, always within voltage and frequency tolerances and has a pure noise-free sinusoidal wave shape. Without the proper power, an electrical device (or load) may malfunction, fail prematurely or not operate at all. There are many ways in which electric power can be of poor quality and many more causes of such poor quality power. Many power problems originate in the commercial power grid, which, with its thousands of miles of transmission lines, is subject to weather conditions such as hurricanes, lightning storms, snow, ice, and flooding along with equipment failure, traffic accidents and major switching operations. Also, power problems affecting today's technological equipment are often generated locally within a facility from any number of situations, such as local construction, heavy startup loads, faulty distribution components, and even typical background electrical noise. Widespread use of electronics in everything from home electronics to the control of massive and costly industrial processes has raised the awareness of power quality. The study of power quality, and ways to control it, is a concern for electric utilities, large industrial companies, businesses, and even home users.

B. Various problems of Power Quality

Following are some of the power quality disturbances:

- Transients
- Interruptions
- Sag / Under voltage
- Swell / Over voltage
- Harmonic distortion
- Voltage Spike
- Noise

III. DIFFERENT TYPES FACTS DEVICES

FACTS devices are now a reality and will soon change the way engineers plan and operate power systems. These equipments can be applied in series, shunt or shunt series in transmission line, and controls operation parameters in transmission systems in steady state and system dynamic behavior in transient state. A FACTS is defined by the IEEE as "a power electronic based system and other static equipment that provide control of one or more AC transmission system parameters to enhance controllability and increase power transfer capability."

A. Static synchronous compensator(STATCOM)

STATCOM is applied in shunt in transmission lines and can adjust the required reactive power dynamically and within the capability of the converter. STATCOM operation modes are Reactive power (Var) control mode and Automatic voltage control mode.

B. Static Synchronous Series Compensator(SSSC)

The SSSC is settled in transmission line in series and injects a voltage with controlled magnitude and angle into it. This injected voltage is, directly or indirectly, always used to control the flowing power on the line.

C. Dynamic Voltage Restorer(DVR)

DVR injects a voltage component in series with the supply voltage and therefore can be regarded as a controlled voltage source, compensating voltage sags and swells on the load side. Voltage injection of arbitrary phase with respect to the load current implies active power transfer capability. This active power is transferred via the dc link, and is supplied either by a diode bridge connected to the ac network, a shunt connected PWM converter or by an energy storage device.

D. Unified Power Quality Controller(UPQC)

The best protect for sensitive loads from voltage sources with inadequate quality, is shunt-series connection power conditioner (UPQC) in which the shunt part supplies the required power of the series part in the condition of voltage sags. UPQC is consisted of two PWM converters and a dc link capacitor.

IV. DISTRIBUTION STATIC COMPENSATOR

In power distribution networks, reactive power is the main cause of increasing distribution system losses and various power quality problems. Conventionally, SVCs have been

used in conjunction with passive filters at the distribution level for reactive power compensation and mitigation of power quality problems. Though SVCs are very effective system controllers used to provide reactive power compensation at the transmission level, their limited bandwidth, higher passive element count that increases size and losses, and slower response make them inapt for the modern day distribution requirement. Another compensating system has been proposed by, employing a combination of SVC and active power filter, which can compensate three phase loads in a minimum of two cycles. Thus, a controller which continuously monitors the load voltages and currents to determine the right amount of compensation required by the system and the less response time should be a viable alternative. D-STATCOM has the capacity to overcome the above mentioned drawbacks by providing precise control and fast response during transient and steady state, with reduced foot print and weight. A D-STATCOM is basically a converter based distribution flexible AC transmission controller, sharing many similar concepts with that of a STATCOM used at the transmission level. At the transmission level, STATCOM handles only fundamental reactive power and provides voltage support, while a DSTATCOM is employed at the distribution level or at the load end for dynamic compensation.

DSTATCOM, can be one of the viable alternatives to SVC in a distribution network. Additionally, a D-STATCOM can also behave as a shunt active filter, to eliminate unbalance or distortions in the source current or the supply voltage. Since a D-STATCOM is such a multifunctional device, the main objective of any control algorithm should be to make it flexible and easy to implement, in addition to exploiting its multi functionality to the maximum. Prior to the type of control algorithm incorporated, the choice of converter configuration is an important criterion. The two converter configurations are voltage source converter or current source converter, in addition to passive storage elements, either a capacitor or an inductor respectively. Normally, voltage source converters are preferred due to their smaller size, less heat dissipation and less cost of the capacitor, as compared to an inductor for the same rating. This paper focuses on the comparative study of the control techniques for voltage source converter based DSTATCOM, broadly classified into voltage control DSTATCOM and current control D-STATCOM. Under the former, phase shift control is compared with the latter, considering indirect decoupled current control and regulation of AC bus and DC link voltage with hysteresis current control. The first two schemes have been successfully implemented for STATCOM control at the transmission level, for reactive power compensation, and voltage support and are recently being incorporated to control a D-STATCOM employed at the distribution end. The following indices are considered for comparison - measurement and signal conditioning requirement, performance with varying linear/nonlinear load, THD, DC link voltage variation and switching frequency. The paper briefly describes the salient features of each strategy, with

Flexible D-STATCOM Performance in Mitigating Faults

their merits and demerits. The paper also emphasizes the choice of current control technique, as it significantly affects the performance of a D-STATCOM. A dynamic simulation model of the D-STATCOM has been developed for various control algorithms in Mat lab/Simulation Power System environment.

A. Principle of D-Statcom

A D-STATCOM is a controlled reactive source, which includes a VSC and a DC link capacitor connected in shunt, capable of generating and/or absorbing reactive power. The operating principles of a D-STATCOM are based on the exact equivalence of the conventional rotating synchronous compensator. The AC terminals of the VSC are connected to the PCC through an inductance, which could be a filter inductance or the leakage inductance of the coupling transformer, as shown in Fig.1

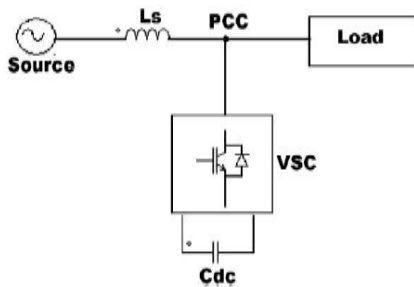

Fig1. Block Diagram of D-Statcom.

The DC side of the converter is connected to a DC capacitor, which carries the input ripple current of the converter and is the main reactive energy storage element. This capacitor could be charged by a battery source, or could be recharged by the converter itself. If the output voltage of the VSC is equal to the AC terminal voltage, no reactive power is delivered to the system. If the output voltage is greater than the AC terminal voltage, the DSTATCOM is in the capacitive mode of operation and vice versa. The quantity of reactive power flow is proportional to the difference in the two voltages. It is to be noted that voltage regulation at PCC and power factor correction cannot be achieved simultaneously. For a DSTATCOM used for voltage regulation at the PCC, the compensation should be such that the supply currents should lead the supply voltages; whereas, for power factor correction, the supply current should be in phase with the supply voltages. The control strategies studied in this paper are applied with a view to studying the performance of a DSTATCOM for power factor correction and harmonic mitigation

B. Features of D-Statcom

The coupling of DSTATCOM is three phase, in parallel to network and load. DSTATCOM injects currents into the point of common coupling. The injected current compensates undesirable components of the load current. There are two possible modes of operation: standard mode and flicker mode.

This mode features four distinct control tasks. A list of priorities can be specified by the customer, defining the most important control tasks for the application at hand. In standard mode, DSTATCOM can perform the following four tasks simultaneously.

1. Active Harmonic Filtering: The current, flowing from the load into the network, is measured, and separated into fundamental and harmonic components. DSTATCOM injects currents such that unwanted harmonic currents are exclusively exchanged between DSTATCOM and the load and therefore do not flow into the network. Rather than a broadband elimination, DSTATCOM filters certain discrete harmonics (e.g. 5th and 7th). Up to four discrete harmonics at a time can be eliminated. The highest harmonic which can be filtered in this manner by the standard equipment is the 13th. As only problematic harmonics are filtered, based on the DSTATCOM power and economical survey.

2. Reactive Power Compensator: DSTATCOM can dynamically supply step-less reactive power, in both capacitive and inductive modes. Power factor control ($\cos\Phi$ - control) is also possible in this mode.

3. Dynamic Load balancing: DSTATCOM can inject both, positive and negative sequence currents into the point of common coupling. It is thus possible to eliminate negative sequence currents associated with unbalanced loads, thereby performing dynamic load balancing.

4. Active Power Transfer: Energy storage devices such as chemical batteries or flywheel systems connected to the dc link capacitor allow energy to be transferred in to the network. A D-STATCOM consists of a two-level VSC, a dc energy storage device, controller and a coupling transformer connected in shunt to the distribution network. Fig 2 shows the schematic diagram of D-STATCOM. Referring to the equation 2, output current will correct the voltage sags by adjusting the voltage drop across the system impedance. It may be mention that the effectiveness of DSTATCOM in correcting voltage sags depends on

- a) The value of Impedance,
- b) The fault level of the load bus

$$I_{out} = I_L - I_S = I_L - \frac{V_{th} - V_L}{Z_{th}} \quad (1)$$

$$I_{out} < \gamma = I_L < (-\theta) - \frac{V_{th}}{Z_{th}} < (\delta - \beta) + \frac{V_L}{Z_{th}} < (-\beta) \quad (2)$$

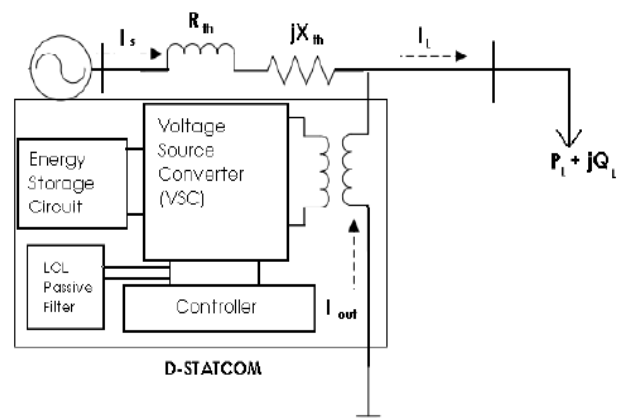

Fig2. Schematic diagram of D-STATCOM.

5. Advantages of D-statcom:

- It is a modified form of STATCOM
- It has better control operational features as compared to STATCOM
- There is no chance of resonance phenomenon.
- It is used for flicker compensation, reactive power compensation and harmonic filtering.

V. RESULTS AND DISCUSSIONS

A. Test System Without Insertion of D-Statcom

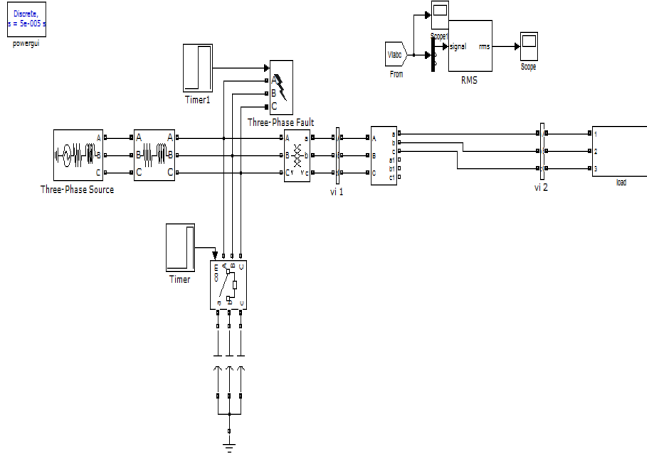

Fig.3 Simulink design diagram of test system without insertion of D-Statcom.

B. Results of Test System without Insertion of DStatcom

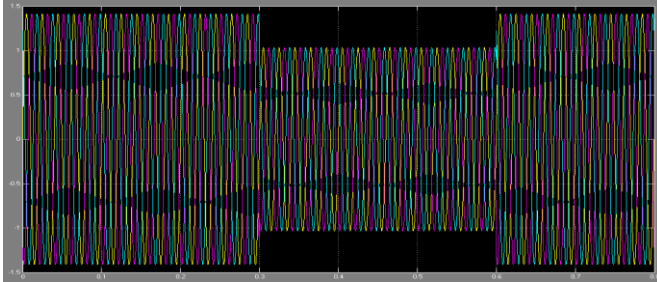

Fig4. Three Phase to Ground -Voltage at Load Point is 0.7300 p.u

C. Testing system with insertion of Proposed D-Statcom

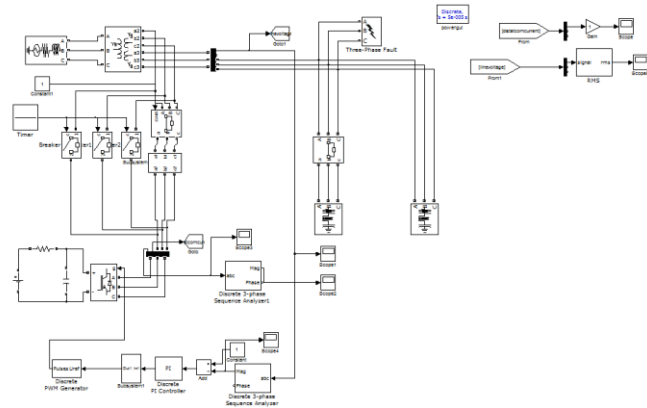

Fig5. Simulink Design Diagram with Insertion of Proposed DStatcom.

D. Results of Insertion of D-Statcom

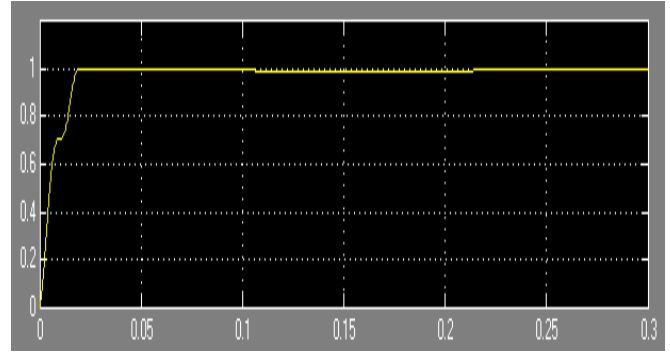

Fig.6 Single Line to Ground - Voltage at Load Point is 0.9863pu.

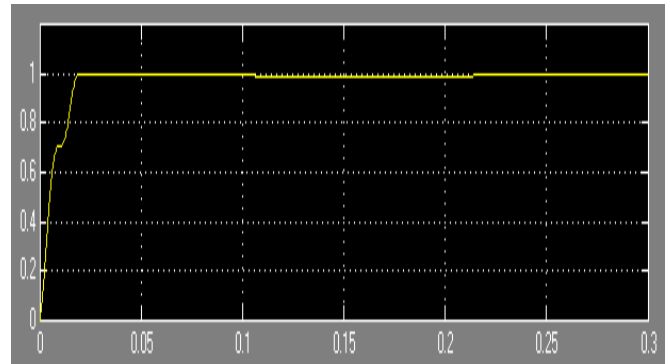

Fig7. Double Line to Ground- Voltage at Load Point is 0.9858 p.u.

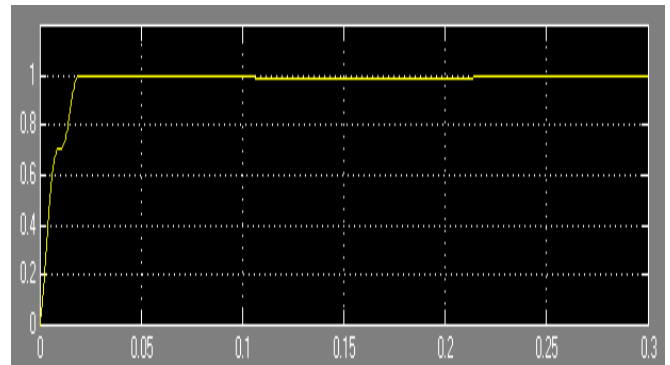

Fig.8. Three Phase to Ground-Voltage at Load Point is 0.9542 p.u.

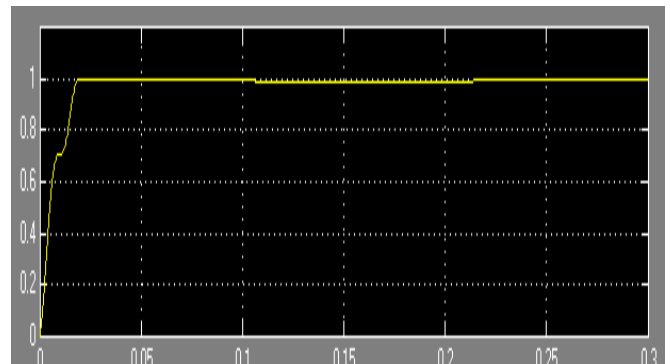

Fig.9 Line to Line - Voltage at Load Point is 1.015 p.u.

Flexible D-STATCOM Performance in Mitigating Faults

Table 1. Comparison of THD results Between without Insertion, Insertion of LCL filter and Insertion of LLCL filter

Type of fault	Without DSTATCOM IN(%)	With Traditional DSTATCOM IN(%)	With Proposed DSTATCOM IN(%)
TPG	87.35	5.28	4.45
DLG	41.35	4.29	3.85
SLG	21.28	1.11	1.09
LL	24.56	1.29	1.16

VI. CONCLUSION

In this paper, a flexible D-STATCOM is proposed that could both mitigate unbalanced faults (such as LL and DLG faults) and operate as a DG, when it supplies power to sensitive loads while the main utility source is disconnected. As a result, D-STATCOM operates same as a FDG and consequently, it is called FD-STATCOM. In addition, this paper has proposed a new control method for mitigating the voltage sags, caused by unbalanced faults and islanding condition, at the PCC. The simulation results show that the voltage sags can be mitigate by inserting D-STATCOM to the distribution system. By adding LLCL Passive filter to D-STATCOM, the THD reduced. The power factors also increase close to unity. Thus, it can be concluded that by adding DSTATCOM with LCL filter the power quality is improved.

VII. REFERENCES

- [1] A.E. Hammad, Comparing the Voltage source capability of Present and future Var Compensation Techniques in Transmission System, IEEE Trans, on Power Delivery. Volume 1. No.1 Jan 1995.
- [2] G.Yalienkaya, M.H.J Bollen, P.A. Crossley, "Characterization of Voltage Sags in Industrial Distribution System", IEEE transactions on industry applications, volume 34, No. 4, July/August, PP.682-688, 1999
- [3] Haque, M.H., "Compensation of Distribution Systems Voltage sags by DVR and D STATCOM", Power Tech Proceedings, 2001 IEEE Porto, Volume 1, PP.10-13, September 2001.
- [4] Anaya-Lara O, Acha E., "Modeling and Analysis Of Custom Power Systems by PSCAD/EMTDC", IEEE Transactions on Power Delivery, Volume 17, Issue: 2002, Pages: 266 272.
- [5] Bollen, M.H.J., "Voltage sags in Three Phase Systems", Power Engineering Review, IEEE, Volume 21, Issue: 9, September 2001, PP: 11-
- [6] M.Madrigal, E.Acha. "Modelling OF Custom Power Equipment Using Harmonics Domain Twchniques", IEEE 2000
- [7] R.Meinski, R.Pawelek, I.Wasiak, "Shunt Compensation For Power Quality Improvement Using a STATCOM controller Modelling and Simulation", IEEE Proce, Volume 151, No.March 2004.
- [8] J.Nastran, R. Cajhen, M. Seliger, and P.Jereb, "Active Power Filters for Nonlinear AC loads, IEEE Trans.on Power Electronics Volume 9, No.1, PP: 92-96, Jan 2004.